

Uniclass L414	EPIC D15
Cl/SfB I (37.4) X I	

Issue 1

Thermadome

POLYCARBONATE ROOFLIGHT RANGE

Thermadome

POLYCARBONATE ROOFLIGHT RANGE

Natural daylight has long been recognised as the most effective form of light. Building Regulation Approved Document L requires designers to provide adequate daylight. '...Where rooflight areas are reduced below 20%, the building designer must take special care to demonstrate daylight levels remain adequate...'. Flat roof rooflights are the most efficient means of providing natural daylight, giving three times more daylight than an equally sized vertical window. The light from a rooflight is also more evenly distributed throughout the room, less likely to result in glare and does not compromise privacy.

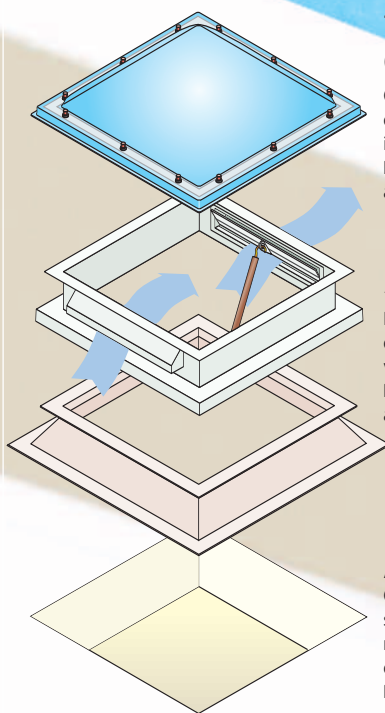

Thermadome glazing

Choice of single, double or triple glazed rooflights in clear, opal diffused or bronze polycarbonate and acrylic glazing.

Accessories

Permanent, controllable, opening or powered ventilation, access hatches, security bars and smoke ventilation.

Preformed kerbs

A range of insulated GRP and PVC-u splayed kerbs, purpose made aluminium kerbs, or fixed direct to builder's kerb.



THERMADOME

Contents

Thermadome glazing	4
Upstand kerbs	6
Security	8
Roof access & ventilation overview	9
Access hatches	10
Ventilation	12
Smoke ventilators	14
Standards and regulations	16
Sitework and installation	17
Product selector	18

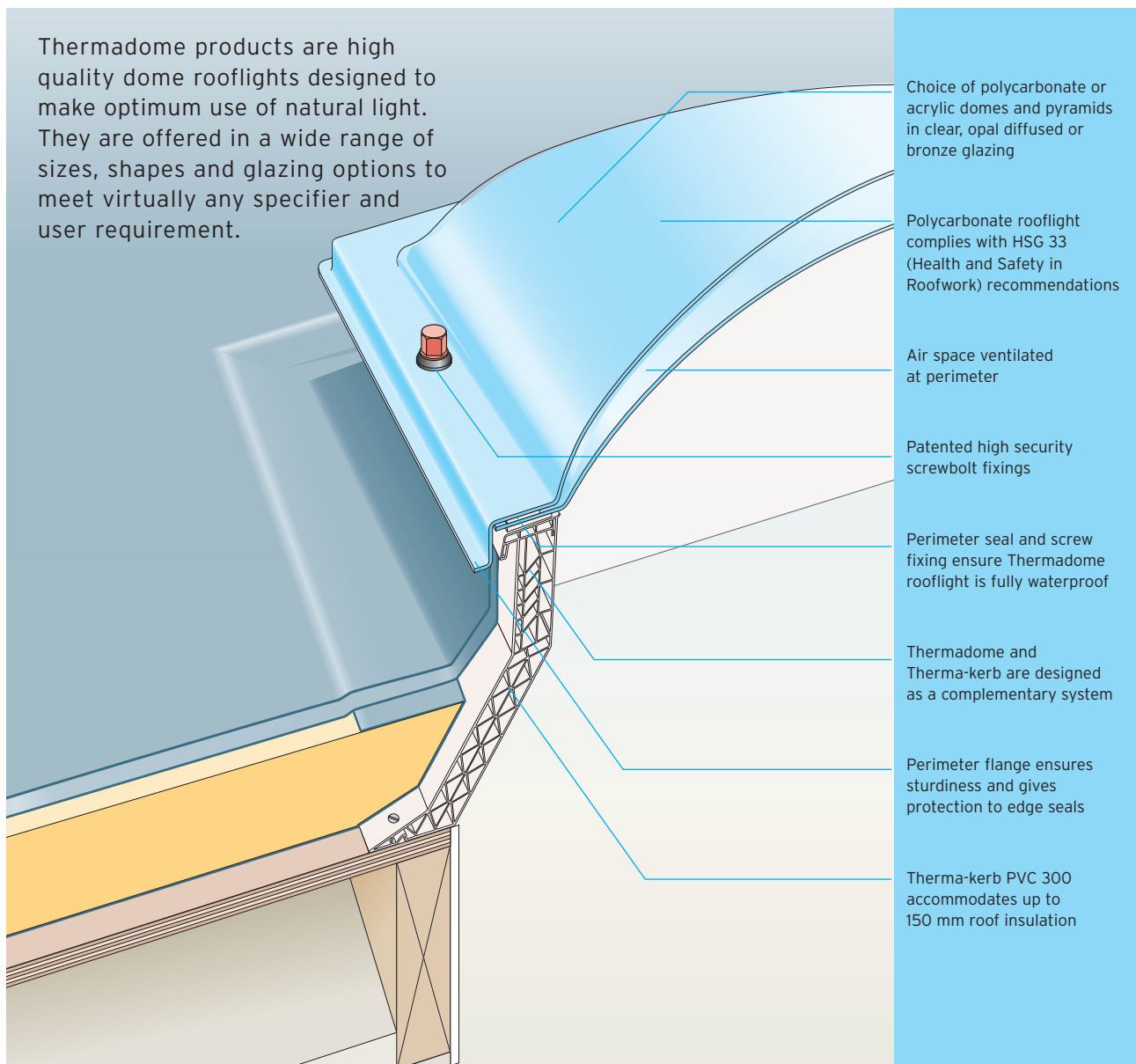

Glazing options

Thermadomes are thermoformed from either polycarbonate or acrylic sheet and are available in single, double or triple skin construction. Polycarbonate is virtually unbreakable, with an impact strength 250 times greater than glass. Acrylic has an impact strength 10 times greater than glass.

Thermadomes can be supplied in clear, opal diffused, bronze or 'Heatstop' (reflecting up to 68% of the heat radiation) glazing.

All polycarbonate Thermadomes use a minimum 3 mm thick glazing. Acrylic Thermadomes have a minimum 3 mm outer skin. Inner skin thickness varies according to the dome size.

Shape

Dome shaped Thermadomes are available square, rectangular or circular. Pyramids are available in square or rectangular units. A limited range of triangular pyramid Thermadomes are available.

Sizes

Offered in an extensive range of sizes from 400 x 400 mm to 1700 x 2900 mm. Many sizes are available ex-stock for immediate delivery. Refer to pages 16 - 18 for full details.

Performance

When installed in accordance with the manufacturers' recommendations, Thermadomes are expected to exceed the life of the roof covering. Thermadomes are guaranteed against the effects of defective design, materials or construction for ten years, subject to certain conditions.

Condensation

Condensation occurs where warm moist air meets cold surfaces. As warm air rises, the risk of condensation forming at rooflight level is relatively greater than at lower level. The risk can be minimised by specifying double or triple skin Thermadomes and Therma-kerb insulated upstands. The provision of ventilation may also assist - see options on page 10 and 11. However, because temperature and humidity levels are clearly beyond our control, no guarantee can be given against the formation of condensation.

Supply

Thermadomes are factory assembled and supplied with high security screwbolt fixings and sealing tape.

Many sizes are available ex-stock for immediate delivery. Refer to pages 16 - 18 for full details on availability.

Technical services

Advice and technical assistance on the application and specification of Thermadome rooflights and accessories is always available from National Domelight Company—see back page for contact details.



Performance of glazing materials

Typical values	Polycarbonate	Acrylic
Fire ratings		
BS 476: Part 3	AA	DD
BS 476: Part 7	Class1*	-
1991 Building Regulations	Tp(a)	Tp(b)
Light transmission		
Clear	86%	92%
Opal diffused	50%	83%
Bronze	46%	55%
Service temperature	-50 to +120°C	-30 to +70°C

Notes: Information for 3 mm thick glazing unless noted otherwise.
* Class O for Building Regulation purposes.

Sound insulation - please contact National Domelight Company for sound reduction levels.

Thermal transmission

Typical values		U-value (W/m ² K)
Single glazed		5.51
Double glazed		2.90
Triple glazed		1.30*

*Measured in hot box in the vertical plane according to BS EN ISO 12567-2:2005

Standard rooflight



Pyramid rooflight

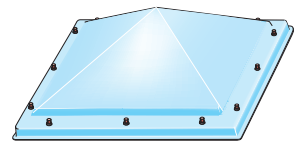

Trapezoidal rooflight

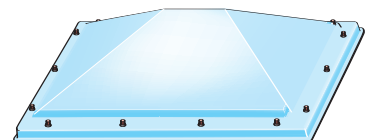



Thermadomes are supplied complete with Screwbolt fixings and packed to minimise damage

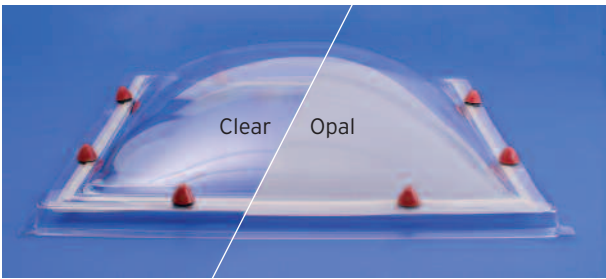

Thermadomes are available in clear, bronze and opal diffused glazing

High security screwbolt

High security screwbolts are supplied as standard to all Thermadome rooflights. Once installed, the fixing cannot be removed. The bolt provides a high level of resistance to tampering or forced entry.

The fixing screw or bolt is sleeved within the body of the screwbolt. This avoids pressure being exerted on the rooflight glazing as the fixing is tightened. This virtually eliminates the risk of stress fractures caused by over-tightening.

Standard screwbolt fixing

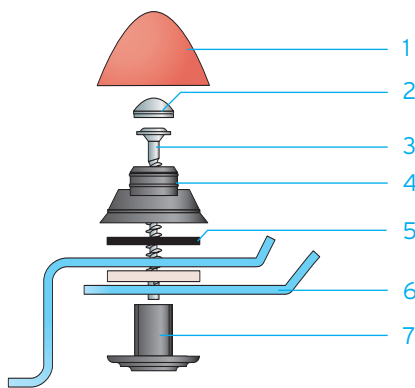

- 1 Security cap
- 2 Internal cap as additional security feature
- 3 One-way clutch-head fixing supplied as standard
- 4 Upper screwbolt section made from strong, rustproof polyacetal
- 5 Rubber washer
- 6 Rooflight glazing
- 7 Lower screwbolt section

Building regulations

Approved Document L

Building Regulations Approved Document L (ADL) 2006 provides regulatory requirements and guidance to achieve reductions in carbon dioxide (CO₂) emissions to the environment from the use of new and refurbished buildings. In ADL 1A and 2A the annual CO₂ emission rate of the new buildings is calculated using approved software such as the Standard Assessment Procedure (SAP) for dwellings and the Simplified Building Energy Model (SBEM) for other buildings.

Implications for rooflights

In ADL 1A and 2A the maximum average U-value for rooflights is 2.2 W/m²K. A poorer performance of 3.3 W/m²K is permissible for individual rooflights provided this is offset by improved performance in other areas to give an area weighted average of 2.2 W/m²K for all rooflights in the building. The U-value of a rooflight is calculated from the combined performance of the glazing and the upstand. As the thermal performance of the glazing and upstand are generally different, even where the specification of the glazing and upstand are consistent for a range of rooflights, individual rooflights are likely to have slightly different U-values due to variations in size. U-values should preferably be obtained by measurement in a hot box according to BS EN ISO 12567-2: 2005.

Optimum rooflight provision

A building's design will affect the contribution rooflights can make. The optimum area of rooflights will therefore vary for each building. However, research has shown that a rooflight area of 15-20% will contribute to an overall reduction in CO₂ emissions in most buildings. Rooflights are three times more effective at supplying daylight than vertical windows. Where artificial lighting is controlled by daylight sensors, installing rooflights can result in a significant reduction in the energy used for lighting. Energy consumed in lighting a building is often greater than that used to heat it.

In addition, the SAP and SBEM software programs take account of the contribution made by passive solar gains through rooflights. Solar gains help to offset the increased heat loss of rooflights compared to the insulated main roof.

Therma-kerbs

Thermadome kerbs are designed to be used in conjunction with Thermadome rooflights and are finished in white internally. Therma-kerbs represent excellent value for money and will enhance the overall appearance of the rooflight. The heights of Therma-kerbs are 150 mm, 300 mm and 500 mm.

The standard Therma-kerb is made from extruded white PVC-u. The multi-chambered construction gives an exceptionally robust and thermally efficient performance. This kerb is suitable for most roof finishes.

Therma-kerbs can also be supplied in GRP which have integral 10 mm polyurethane foam insulation and robust dome fixing and mounting flanges. It can be used with any roofing material.

Special GRP versions are also available 150, 300 and 500 mm high. These have 20 mm of integral insulation.

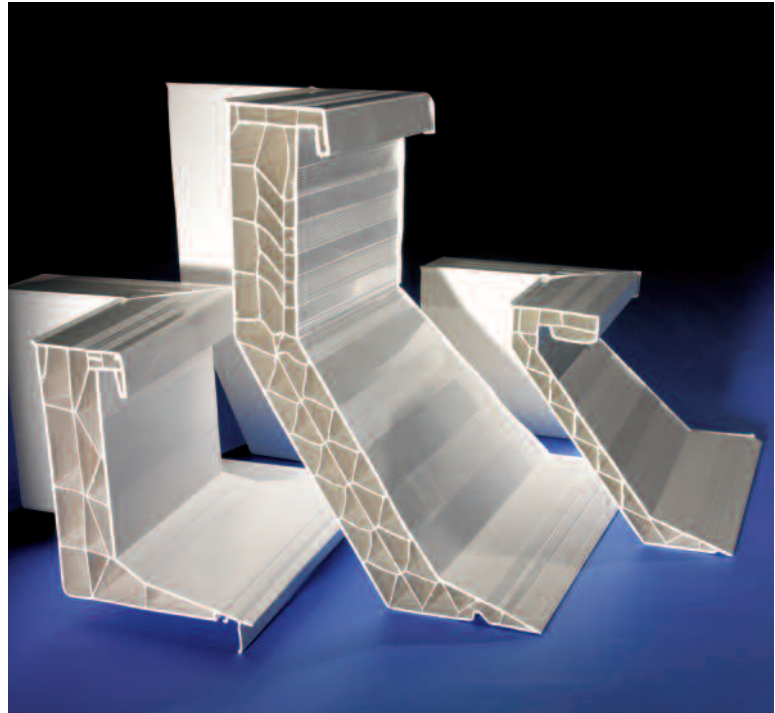

Thermal transmission

Typical values	U-value (W/m ² K)
Thermadome kerbs PVC-u 150/s	2.20
150/v	1.00*
300/s	1.00*
Thermadome kerbs GRP Standard 150 mm high	1.82
Special 150, 300 and 500 mm high	1.07

*Measured in hot box in the vertical plane according to BS EN ISO 12567-2:2005

Therma-kerb PVC-u 150/s

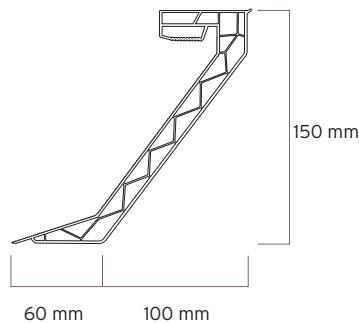

Therma-kerb PVC-u 150/v

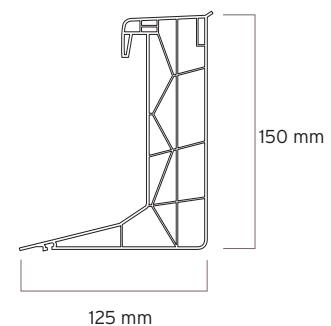

Therma-kerb PVC-u 300/s

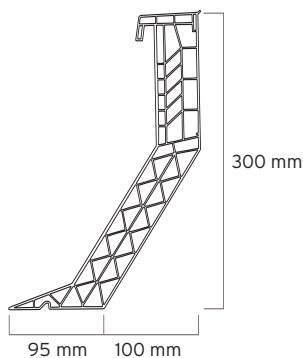

Therma-kerb GRP 150- Standard

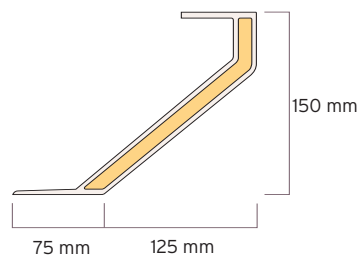

Therma-kerb GRP (150),
300 and (500 mm)-Special

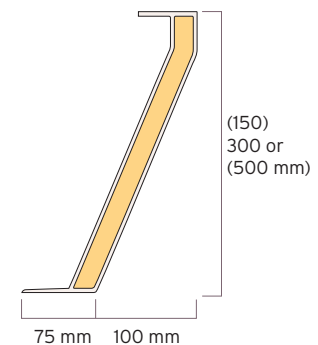

Alu-kerbs

Alu-kerbs are purpose made to fit non-standard roof openings. Alu-kerbs are fabricated from mill finished aluminium in an all-welded construction and supplied with a white foamed PVC-u insulating lining as standard. If required, additional insulation can be applied externally prior to waterproofing.

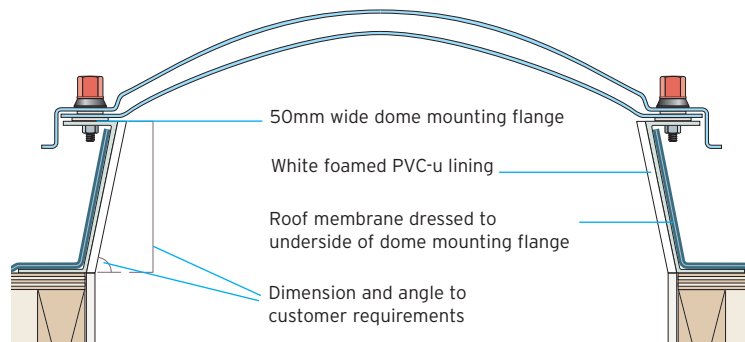

Alu-kerb adaptors, collars and flanges

Alu-kerb adaptors, collars and flanges enable standard sized Thermadomes to be fitted where a direct size match is not available. They are purpose made to fit any size or type of existing builder's kerb or proprietary upstand.

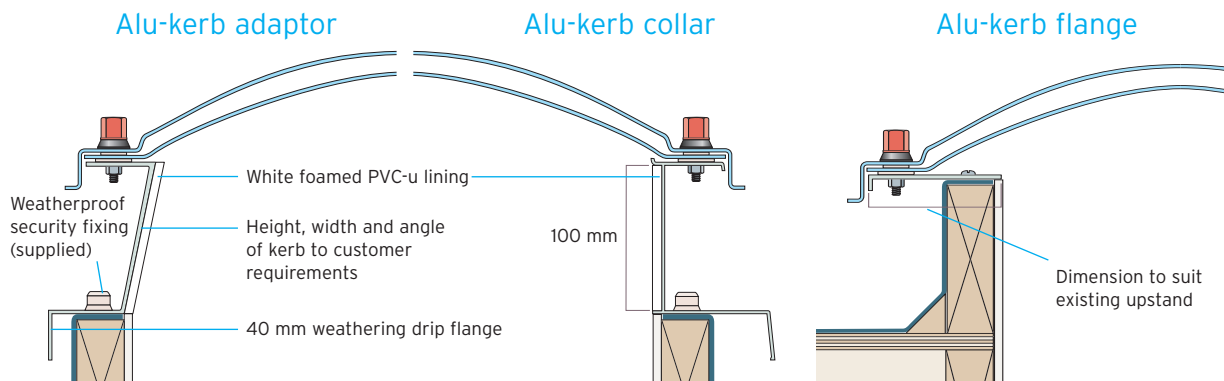

Multiple rooflights

For extra long applications, eg 3-6 m, two or more Thermadomes can be installed together by means of linked Alu-kerb Adaptors. These are self-supporting up to a span of 1m. For spans over 1m a structural support is required. Where necessary, linked Alu-kerb Adaptors are supplied in individual sections for jointing on site, utilising a standing seam detail.

For roof openings longer than 6 m, we would normally recommend a continuous barrel vault rooflight.

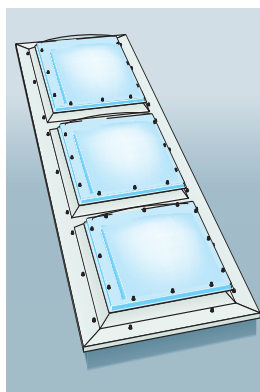

Linked Alu-kerb adaptor jointing detail

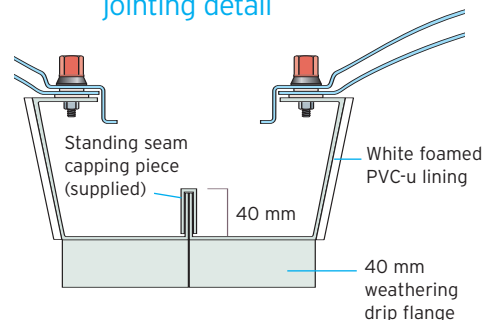

Thermadome Plus

Thermadome Plus is a fully enclosed, tamper-proof frame for a totally secure fixing. Thermadome Plus is simple to install and provides a neat, unobtrusive appearance, with no visible fixings. The design of the frame allows for a completely weatherproof, self-draining construction, incorporating standard Thermadomes in single, double or triple skin construction.

Appearance

The Thermadome Plus frame is made from aluminium extrusions to BS 1474, Quality 6063/T6, and is available ex-stock in mill finish. Polyester powder coated frames are also available to special order.

Performance

Thermadome Plus security rooflights will not rust and are not affected by atmospheric pollution. Once installed, they are maintenance free.

Sitework

The frame is supplied in two parts. If supplied with Thermo-kerb or Alu-kerb, the frame is factory fitted. For mounting to builder's kerb, screw-fix the frame to the kerb as shown. The top frame is simply snap fixed into place.

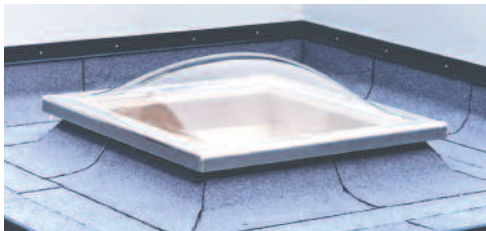

Fixing Thermadome Plus to builder's kerb

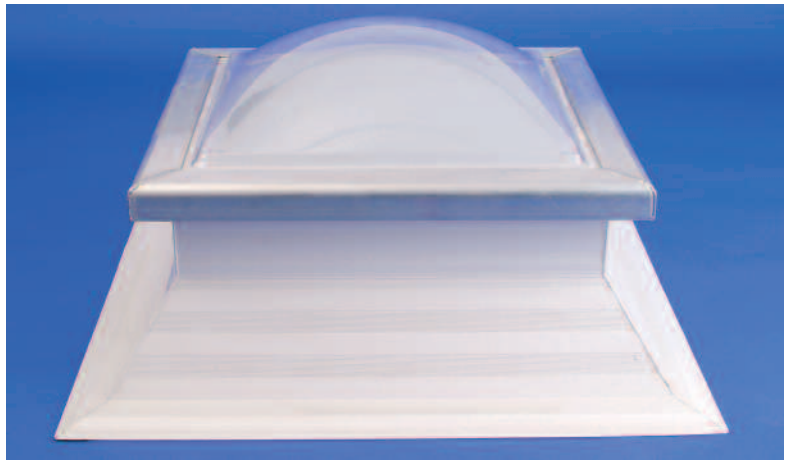
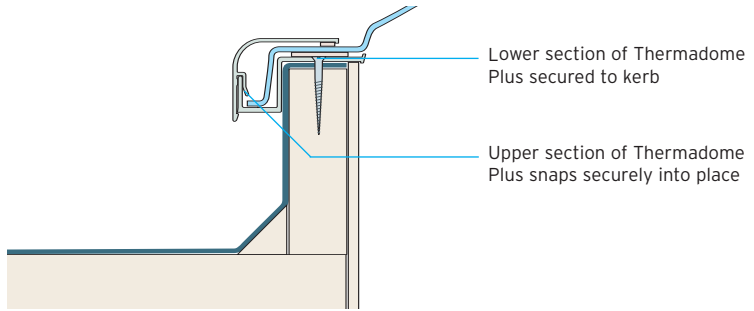

Fixing Thermadome Plus to Thermo-kerb

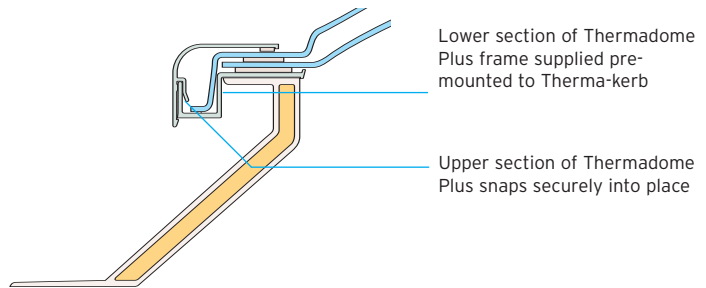

Burglar bars

Where a higher level of security is required white Polyester Powder Coated burglar bars are available in most sizes and permutations.

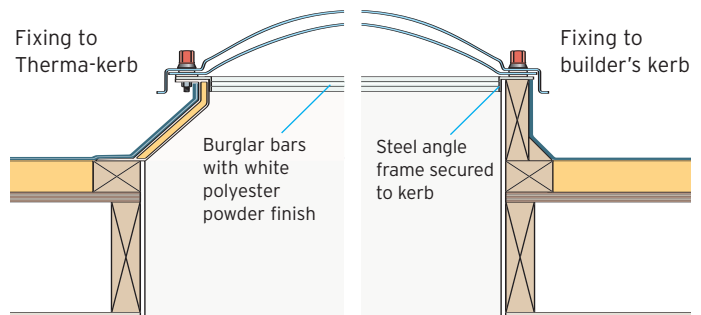
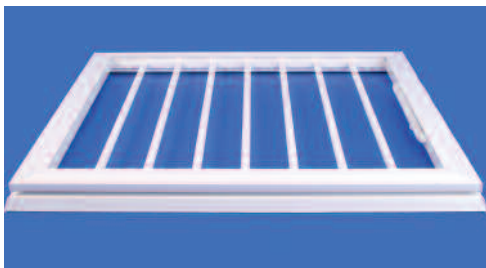

Access hatches

Where the rooflight is to be used as a means of access on to a roof, a fully opening frame can be specified for mounting either direct to a builder's kerb or in conjunction with Therma-kerb and Alu-kerb upstands or Alu-kerb adaptors.

PVC-u frames are for use with Therma-kerb and Alu-kerb upstands. Aluminium frames are for use with builder's kerbs.

Standard features include a locking handle to secure the rooflight in the closed position and telescopic struts to hold the rooflight in the open position. The telescopic struts have adjustable friction control and can be set according to dome weight and prevailing site conditions. Therma-hatch can be

supplied with Thermadome thermoformed polycarbonate glazing or insulated aluminium cover.

Access hatches are not recommended in sizes larger than 1160mm square or 860 x 1460 rectangular.

Therma-hatch–PVC-u frame mounted to Therma-kerb

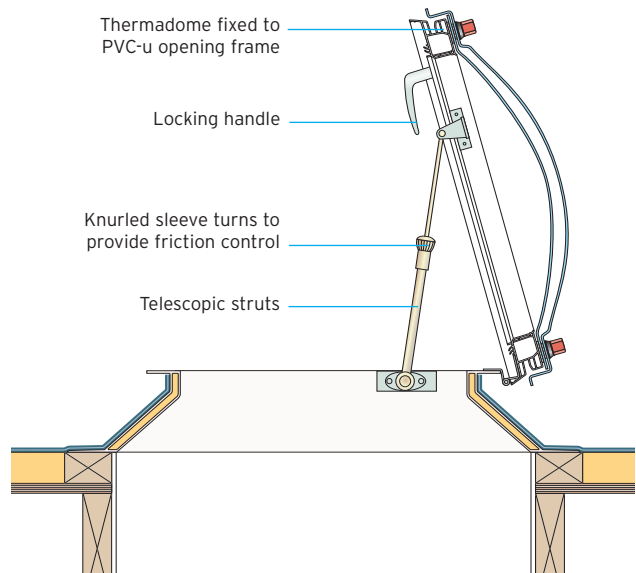

Therma-hatch–PVC-u frame mounted to Builder's kerb

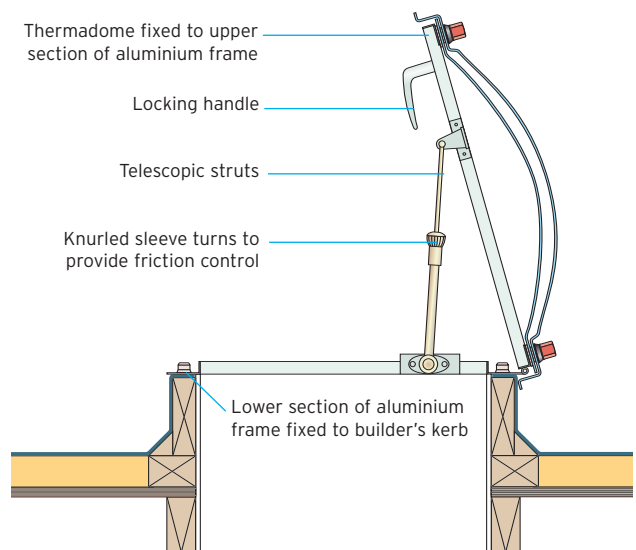
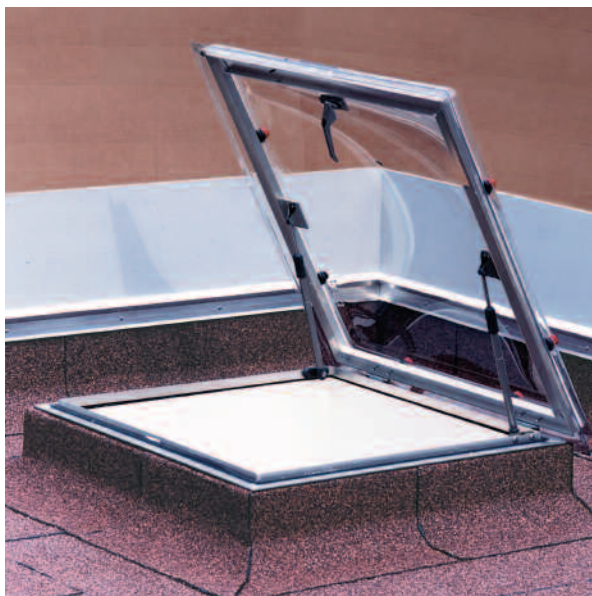

Trickle ventilation

Permanent trickle ventilation

Permanent ventilation is provided by means of spacer washers inserted in the Thermadome fixings. A gap of 5-10 mm can be provided around the complete perimeter, without compromising the security or weather protection of the rooflight.

Controlled trickle ventilation

Trickle ventilators can be factory fitted to the top of Therma-kerb PVC 150 and 300 mm or PVC opening frames.

The vents are fitted to two sides as standard and will provide background ventilation of 8000 mm² to satisfy the requirements of Building Regulations.

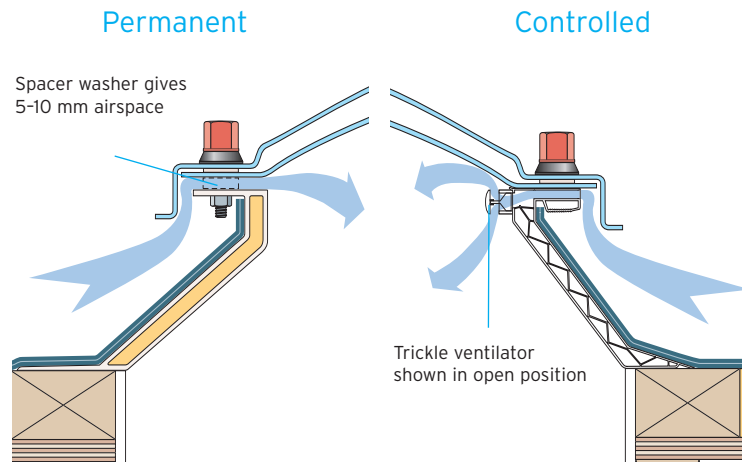

Controlled louvre ventilation

A vent collar unit fitted with adjustable louvres is located between the rooflight dome and the builders kerb. Units are available as a 100 mm high aluminium collar with white foamed PVCu insulating lining internally or a 150mm high white multi-chambered PVCu collar. The vents are fitted to two opposite sides as standard. All four sides may be fitted with vents, if higher levels of airflow are required.

For Alu-kerbs, Alu-kerb adaptors and Therma-kerbs 300 mm high, the vents and cowls are fitted directly in the side wall.

The fully adjustable louvre vents are operated by means of a hooked rod, available in lengths of 1.5, 2 or 3 m. The louvres are protected from the elements by an external weather cowl.

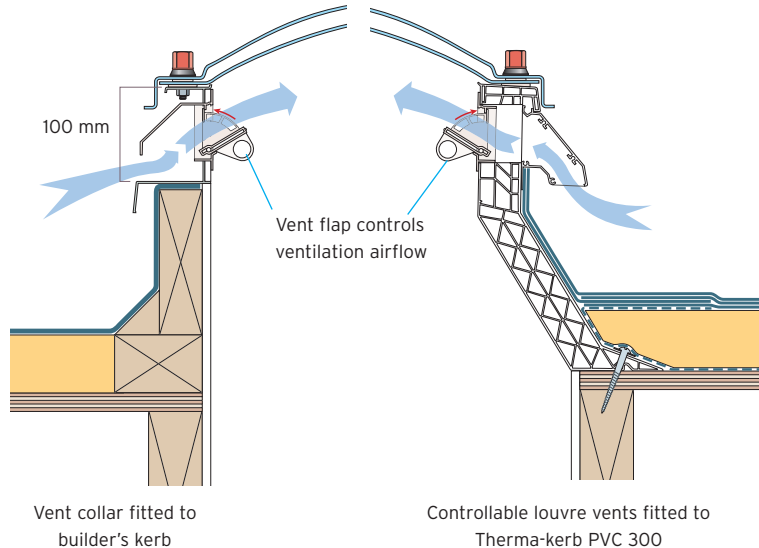

Powered ventilation

Where natural ventilation is insufficient, Thermadome can be supplied with Vent Axia Solo centrifugal extract fans. These are mounted in the side wall of Therma-kerb PVC-u 150/v or Therma-kerb PVC-u 300/s.

These high performance extract fans are specifically designed for ventilating internal bathrooms, WC's and other small rooms. They have an extract performance of 85 m³/hr (24 l/s) and can be fitted in one or more sides. Where greater air movement is required, white PVC lined fan collars with pre-cut apertures are available to enable fitting of larger axial fans (eg Vent-Axia T-series).

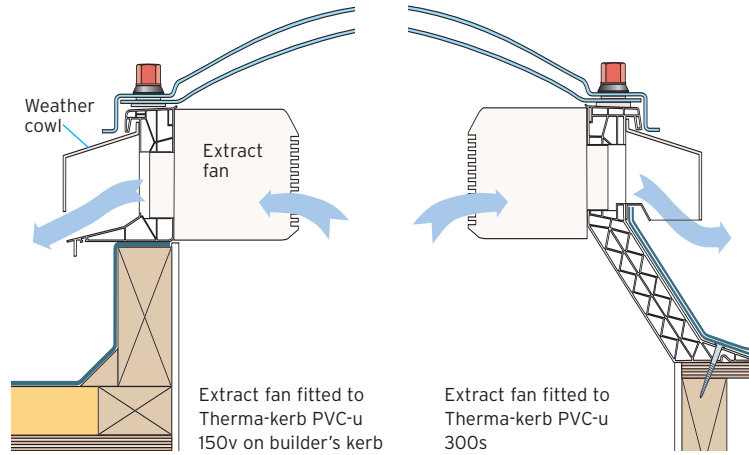

Opening ventilation

Where maximum natural air movement is required, Thermadomes can be supplied fitted with hinged opening frames, with a manual spindle operated by a winding rod (or electric motor for remote control). Where the hinged side exceeds 1.3 m a tandem spindle unit is fitted.

Frames are constructed from PVC-u, for use when fitted to Therma-kerb or Alu-kerb upstands. Alternatively, where mounting directly to a builder's kerb, an aluminium frame is supplied.

Electric motors are supplied complete with open/close switches (wiring by others) and can be specified to open up to 600 mm as an extra cost option.

Insect screens are available in most sizes when supplied with Therma-kerbs or Alu-kerb upstands and manual opening frames.

PVC-u frame pre-mounted to Therma-kerb

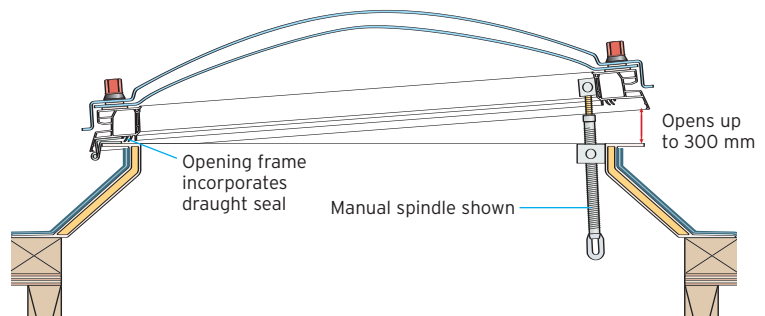

Aluminium frame mounted on builder's kerb

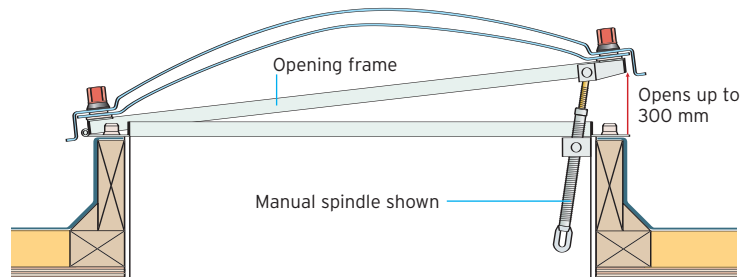

Therma-vent smoke ventilators

Therma-vent smoke ventilators are designed to reduce smoke build-up, thus providing a safer escape route for occupants, and access for fire-fighting personnel. The system can also be utilised to provide natural ventilation.

A typical smoke ventilation system includes Therma-vent smoke ventilators (Opening Vents (OVs) or Automatic Opening Vents (AOVs)) located at the highest point of an escape route staircase or at the top of a smoke shaft. Smoke detectors and manual control points are normally located on each floor. The system can be controlled by a Therma-vent control panel.

In the event of a fire the smoke detectors on the relevant floor instruct the control panel to operate the Therma-vent AOV creating an upward air flow, venting smoke and toxic gases.

The system can be designed to automatically open on receipt of a fire signal or be controlled by the Therma-vent control panel on instruction of the fire services. Alternatively the Therma-vent AOVs can be linked to the Building Management System (BMS) for complete monitoring.

Building regulations

The design of natural smoke ventilation systems for buildings is governed by Building Regulation Approved Document B. For residential buildings the basic requirements of Approved Document B state that a smoke ventilation system must be provided if the travel distance between an apartment door and the nearest escape stair is greater than 7.5 metres.

National Domelight Company Therma-vents can satisfy Building Regulations including Approved Document B and European Standards EN12101 as part of a designed smoke ventilation system.

The responsibility for determining that any building component complies with the relevant Regulation rests solely with the customer or specifier. For further information and technical assistance please contact National Domelight Company.

Therma-vent control system

Therma-vent Control Panels supplied as part of a smoke ventilation system can operate up to four AOVs. Accessories include the Therma-vent Optical Smoke Detector with mounting socket and red LED status indication, the Therma-vent Break Glass and Therma-vent Fireman's Key Switch.

The Therma-vent Control Panel is supplied ready to install with batteries fitted and all internal wiring complete and tested. This enables quick installation times with virtually no scope for wiring errors. It is supplied complete with open, close and reset buttons and LED status indicators behind a break glass panel. The LEDs provide instant status indication, showing any system or wiring faults, system activation and vent position. When used with an AOV the priority control will respond to signals from smoke detectors and manual control points and Fireman's Switch in order of importance. For natural ventilation the control panel is supplied with a key to remove the break glass to enable operation of the open / close / reset buttons to operate the AOV.

The Therma-vent Control Panel can be installed to operate as a simple centralised 'stand alone' system or a larger decentralised or 'networked' system with additional Therma-vent Control Panels.

A 'stand alone' Therma-vent Control Panel may be installed to operate on the instruction of the fire service. Alternatively it may be installed to operate on receipt of a fire signal from either a smoke detector or manual control point mounted within the fire zone.

A networked Therma-vent system involves control panels distributed around the building, each controlling a zone with up to four AOVs. This enables cabling distances to be reduced.

Networking requires the installation of an Therma-vent Control Panel within each fire zone. These can be linked to the central control zone utilising Fireman's Switch control points.

Individual zones activated by smoke detectors or manual control points can be overridden by the centrally mounted Fireman's Switches.

Alternatively the Therma-vent Control Panel can be installed as part of a larger system receiving signals from a BMS via its 'no voltage' monitoring capacity.

Smoke hatches - OV's (Opening Vents) and AOV's (Automatic Opening Vents)

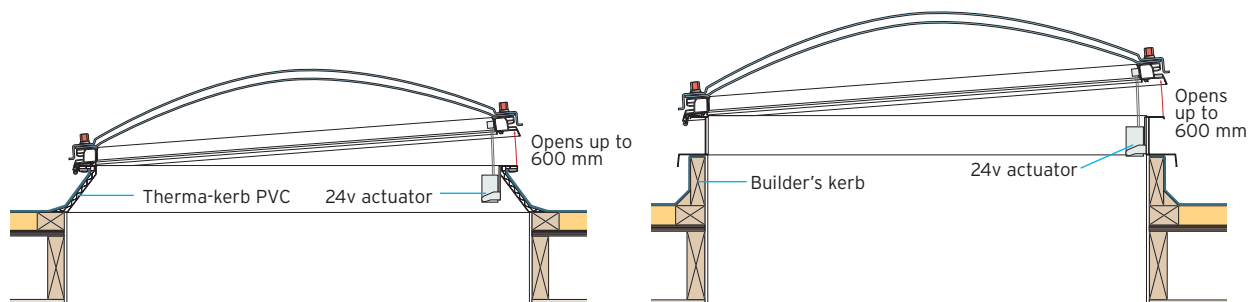

Stand alone system

This drawing shows a centralised 'stand alone' Therma-vent Smoke Ventilation system installed in an escape route staircase. Manual control points activate the OV.

NB: Units open 400 mm or 600 mm as standard. Some sizes available to 90° or 140°.

Key

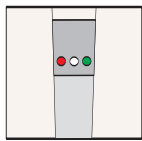

Therma-vent Control Panel



Smoke detector



Manual control point



Fireman's Switch control point

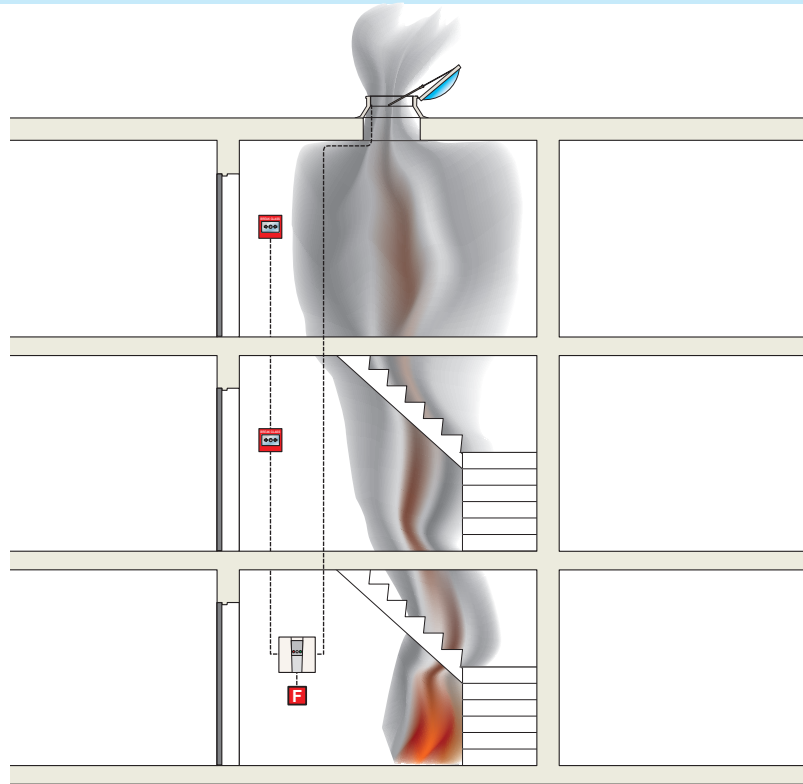

Networked system

Networked Therma-vent Smoke Ventilation system installed in living accommodation, escape route staircase and smoke shaft. Smoke detectors and manual control points activate the AOV. Fireman's Switches enable central control.

NB: Units open 400 mm or 600 mm as standard. Some sizes available to 90° or 140°.



Health and Safety

According to the Health and Safety Executive, almost 20% of deaths in the construction industry are caused by falls from or through roofs. The majority of these falls are through fragile materials such as asbestos cement roofing or old/fragile rooflights.

The Construction (Design and Management) Regulations 1994 places a duty on designers and specifiers to give proper consideration to eliminating or reducing risks at the design stage. HSG 33 *Health and Safety in Roof Work* (October 1998) draws attention to the responsibilities of those specifying rooflights.

HSG 33 states that where rooflights are required, designers should consider:

- specifying rooflights that are non-fragile
- fitting rooflights designed to project above the plane of the roof and which cannot be walked on (these reduce the risk but they should still be capable of withstanding a person falling onto them)
- protecting rooflights, eg: by means of mesh or grids fitted below or above the rooflight
- specifying rooflights with a design life that matches that of the roof, taking account of the likely deterioration due to ultraviolet exposure, environmental pollution and internal and external building environment.

For specifiers the key message is to eliminate 'fragile' materials from roof design. For contractors, provide effective fall arrest equipment or safety netting.

BS 6229

BS 6229: 1982, *Code of practice for flat roofs with continuously supported coverings*, requires rooflights to incorporate upstands to raise them at least 150 mm above the uppermost roof surface to which the roof covering is bonded or dressed.

The standard 150 mm high Therma-kerbs comply with this. Higher Therma-kerbs should be used where insulation is located above the lower flange of the Kerb—see detail on page 15.

National Domelight Company's Thermadome rooflights are 'out-of-plane' rooflights, and provided they are specified with polycarbonate glazing, can be deemed to be 'non-fragile'.

- National Domelight Company's Thermadome polycarbonate rooflights have undergone large body impact testing by an independent accredited test organisation and test certificates are available to demonstrate compliance to an energy level of 1200J when tested to pr EN 1873.
- National Domelight Company offer a 10 year warranty against discolouration of Thermodomos glazing material and, in the case of polycarbonate, loss of impact strength, underwritten by the sheet material supplier.
- National Domelight Company polycarbonate Thermodomos have been awarded BBA certificate No 01/1384 or are manufactured to BS ISO 9001.
- National Domelight Company offer a post-forming warranty backed by the sheet manufacturer.



Acrylic rooflights are classified as 'fragile' and have a lesser fire rating than polycarbonate and should therefore be specified accordingly.

Building regulations

For details on Building Regulations Approved Documents B *Fire safety* and L *Conservation of fuel and power* see page 5.

Handling and storage

While all Thermadome rooflights and associated products are suitably packaged to avoid damage care should be exercised when handling. For moving larger items, two or more people may be needed. All products should be stored on edge in flat dry conditions.

Installation

All Thermadomes are supplied ready assembled and pre-drilled complete with security screwbolts and factory applied sealing tape and are delivered to site in protective packaging and with all fixings. Full instructions and fixings are included with all products, and should be carefully studied prior to installation.

Fixing upstand kerbs

For fixing kerbs to the roof structure, drill holes in the bottom flange, 100 mm from each corner and at maximum 300 mm centres and screw to roof structure. Typical installation details are shown below. The PVC-u Therma-kerb is suitable for use with single ply membranes and all bitumen finishes. Where asphalt is specified, National Dometlight Company recommend the use of GRP Therma-kerbs.

Fixing Thermadomes to Therma-kerbs

The Thermadome should be accurately positioned on the Therma-kerb and the Screwbolt fixing positions marked on the Therma-kerbs. The fixing holes are drilled in the Therma-kerb and the Thermadome is simply placed in position and fixed using the Screwbolt fixings supplied.

Fixing Thermadome to builder's kerbs

The Thermadome should be 60 mm bigger than the outside dimensions of the upstand kerb. Holes should be pre-drilled in the upstand kerb to accept the tamper-proof screws provided for use with the Screwbolt fixings. The fixing positions can be located by accurately placing the dome over the upstand kerb, with the Screwbolt caps removed, and marking the position of the fixings.

Maintenance

In normal weather and site conditions, only occasional cleaning is necessary. Use only diluted household detergent and test on small area first. Do not use chemical solvent or abrasive cleaners. No other maintenance should be necessary.

Insulated roof–150 mm high upstand

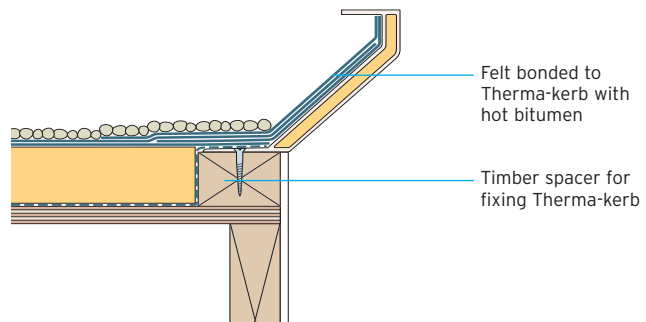

Insulated roof–300 mm high upstand

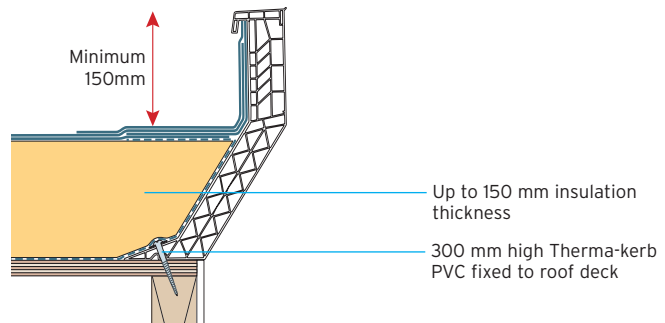

Rooflight dimensions with Therma-kerb

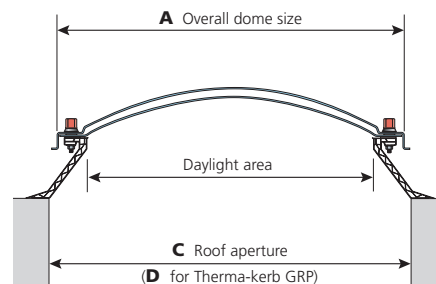

Note: See pages 16 - 18 for dimensions A, C and D

Rooflight dimensions with builder's kerb

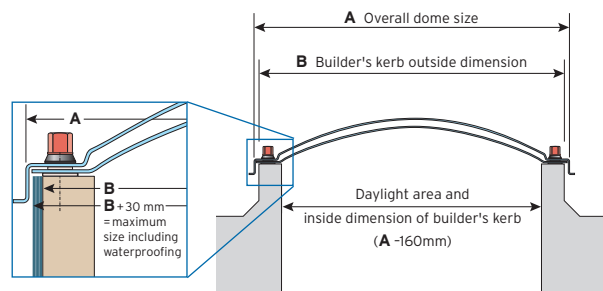

Note: See pages 16 - 18 for dimensions A and B

Product range and availability

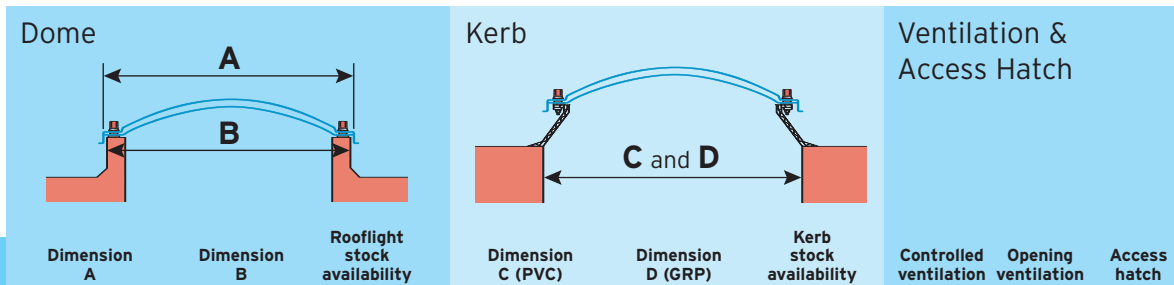

Size Ref No.	Dimension A	Dimension B	Rooflight stock availability	Dimension C (PVC)	Dimension D (GRP)	Kerb stock availability	Controlled ventilation	Opening ventilation	Access hatch
Square rooflights									
TD-S0	460 x 460	400 x 400	☐	500 x 500	500 x 500	☐		☐	
TD-S1	560 x 560	500 x 500	■△	600 x 600	650 x 650	■	■	■	
TD-S1a	610 x 610	550 x 550	☐	650 x 650		☐	☐	☐	
TD-S2	660 x 660	600 x 600	■△	700 x 700	750 x 750	■	■	■	■
TD-S3	710 x 710	650 x 650	■	750 x 750	750 x 750	■	■	■	■
TD-S4	760 x 760	700 x 700	■△	800 x 800	850 x 850	■	■	■	■
TD-S5	860 x 860	800 x 800	■△	900 x 900	950 x 950	■	■	■	■
TD-S6	910 x 910	850 x 850	■△	950 x 950	1000 x 1000	■	■	■	■
TD-S7	960 x 960	900 x 900	■△	1000 x 1000	1050 x 1050	■	■	■	■
TD-S7a	1010 x 1010	950 x 950	☐△	1050 x 1050		☐	☐	☐	☐
TD-S8	1060 x 1060	1000 x 1000	■△	1100 x 1100	1150 x 1150	■	■	■	■
TD-S9	1160 x 1160	1100 x 1100	■△	1200 x 1200	1250 x 1250	■	■	■	■
TD-S10	1210 x 1210	1150 x 1150	■	1250 x 1250	1250 x 1250	☐	■	■	
TD-S10a	1260 x 1260	1200 x 1200	■△	1300 x 1300		■	■	■	
TD-S11	1360 x 1360	1300 x 1300	■△	1400 x 1400	1450 x 1450	■	■	■	
TD-S12	1460 x 1460	1400 x 1400	■△	1500 x 1500	1550 x 1550	■	■	■	
TD-S13	1560 x 1560	1500 x 1500	■△	1600 x 1600	1650 x 1650	☐	■	☐	
TD-S14	1660 x 1660	1600 x 1600	☐△	1700 x 1700		☐	☐	☐	
TD-S14a	1710 x 1710	1650 x 1650	☐	1750 x 1750		☐	☐	☐	
TD-S15	1760 x 1760	1700 x 1700	☐△	1800 x 1800	1850 x 1850	☐	☐	☐	
TD-S15a	1860 x 1860	1800 x 1800	■	1900 x 1900		☐	■	☐	
TD-S16	1960 x 1960	1900 x 1900	☐△	2000 x 2000	2050 x 2050	☐	☐	☐	

Circular rooflights									
TD-C1	560 ø	500 ø	●		650 ø	●		●	
TD-C2	660 ø	600 ø	●		750 ø	●		●	
TD-C3	760 ø	700 ø	●		850 ø	●		●	
TD-C4	860 ø	800 ø	●		950 ø	●		●	
TD-C5	960 ø	900 ø	●		1050 ø	●		●	
TD-C6	1060 ø	1000 ø	●		1150 ø	●		●	
TD-C7	1160 ø	1100 ø	●		1250 ø	●		●	
TD-C8	1260 ø	1200 ø	●		1350 ø	●		●	
TD-C8a	1360 ø	1300 ø	○		1450 ø	○		○	
TD-C9	1460 ø	1400 ø	○		1550 ø	○		○	
TD-C9a	1560 ø	1500 ø	○					○	
TD-C10	1760 ø	1700 ø	○		1850 ø	○		○	
TD-C10a	1860 ø	1800 ø	○		1950 ø	○		○	
TD-C11	1960 ø	1900 ø	○		2050 ø	○		○	

Availability

■● available ex-stock, 1 to 5 days delivery ☐○ available to order, 7-28 days delivery △ available in pyramid form

Bronze anti-glare domes = 14 to 28 days delivery. For powered ventilation, burglar bars and multiple rooflights please consult National Domelight Company.

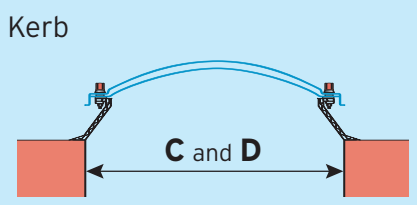
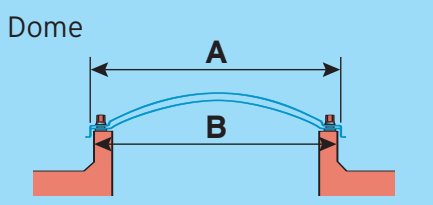

Ventilation & Access Hatch

Size Ref No.	Dimension A	Dimension B	Rooflight stock availability	Dimension C (PVC)	Dimension D (GRP)	Kerb stock availability	Controlled ventilation	Opening ventilation	Access hatch
Rectangular rooflights									
TD-R1	460 x 960	400 x 900	□	500 x 1000	500 x 1000	□	□	□	
TD-R1a	460 x 1060	400 x 1000	□	500 x 1100		□	□	□	
TD-R2	460 x 1460	400 x 1400	□	500 x 1500	500 x 1500	□	□	□	□
TD-R3	560 x 860	500 x 800	■△	600 x 900	650 x 950	■	■	■	■
TD-R3a	560 x 1160	500 x 1100	■△	600 x 1200	650 x 1250	■	■	■	■
TD-R3c	560 x 1460	500 x 1400	□	600 x 1500		□	□	□	□
TD-R3cx	560 x 1660	500 x 1600	□	600 x 1700		□	□	□	□
TD-R3d	560 x 1760	500 x 1700	□	600 x 1800		□	□	□	□
TD-R3x	560 x 2060	500 x 2000	□	600 x 2100		□	□	□	□
TD-R3y	560 x 2360	500 x 2300	□	600 x 2400		□	□	□	□
TD-R3p	610 x 910	550 x 850	□	650 x 950		□	□	□	□
TD-R3r	610 x 1210	550 x 1150	□	650 x 1250		□	□	□	□
TD-R3b	660 x 860	600 x 800	□	700 x 900	750 x 950	□	□	□	□
TD-R4	660 x 960	600 x 900	■△	700 x 1000		■	■	■	■
TD-R4x	660 x 1160	600 x 1100	□	700 x 1200	750 x 1250	□	□	□	□
TD-R4a	660 x 1260	600 x 1200	■△	700 x 1300		■	■	■	■
TD-R4y	660 x 1560	600 x 1500	□	700 x 1600		□	□	□	□
TD-R4b	660 x 1860	600 x 1800	■	700 x 1900		■	■	■	□
TD-R4e	660 x 2160	600 x 2100	□	700 x 2200		□	□	□	□
TD-R4z	660 x 2460	600 x 2400	□	700 x 2500		□	□	□	□
TD-R5x	760 x 960	700 x 900	□	800 x 1000		□	□	□	□
TD-R5	760 x 1060	700 x 1000	■	800 x 1100	850 x 1150	■	■	■	■
TD-R6	760 x 1360	700 x 1300	■	800 x 1400	850 x 1450	■	■	■	□
TD-R6a	760 x 1460	700 x 1400	□	800 x 1500	800 x 1500	□	□	□	□
TD-R6c	760 x 1660	700 x 1600	□	800 x 1700		□	□	□	□
TD-R6f	760 x 1960	700 x 1900	□	800 x 2000		□	□	□	□
TD-R6g	760 x 2060	700 x 2000	□	800 x 2100		□	□	□	□
TD-R6h	760 x 2160	700 x 2100	□	800 x 2200		□	□	□	□
TD-R7	860 x 1160	800 x 1100	■△	900 x 1200	950 x 1250	■	■	■	■
TD-R7a	860 x 1460	800 x 1400	■	900 x 1500	950 x 1550	■	■	■	□
TD-R7d	860 x 1660	800 x 1600	□	900 x 1700		□	□	□	□
TD-R7b	860 x 1760	800 x 1700	■	900 x 1800		■	■	■	□
TD-R7x	860 x 2160	800 x 2100	□	900 x 2200		□	□	□	□
TD-R7y	860 x 2360	800 x 2300	□	900 x 2400		□	□	□	□
TD-R8x	910 x 1210	850 x 1150	□	950 x 1250		□	□	□	□
TD-R8	910 x 1410	850 x 1350	□△	950 x 1450	1000 x 1500	□	□	□	□
TD-R9x	910 x 1810	850 x 1750	□	950 x 1850		□	□	□	□
TD-R9	910 x 1910	850 x 1850	□	950 x 1950	1000 x 2000	□	□	□	□
TD-R10	910 x 2410	850 x 2350	□	950 x 2450	1000 x 2500	□	□	□	□
TD-R10a	960 x 1260	900 x 1200	■△	1000 x 1300		■	■	■	■
TD-R11	960 x 1460	900 x 1400	■△	1000 x 1500	1050 x 1550	■	■	■	□
TD-R11x	960 x 1560	900 x 1500	□	1000 x 1600		□	□	□	□
TD-R11c	960 x 1760	900 x 1700	□	1000 x 1800		□	□	□	□
TD-R11a	960 x 1860	900 x 1800	■	1000 x 1900		■	■	■	□
TD-R12	960 x 1960	900 x 1900	□△	1000 x 2000	1000 x 2000	□	□	□	□
TD-R12b	960 x 2160	900 x 2100	□	1000 x 2200		□	□	□	□
TD-R13	960 x 2360	900 x 2300	□	1000 x 2400	1050 x 2450	□	□	□	□
TD-R14	960 x 2460	900 x 2400	□	1000 x 2500	1000 x 2500	□	□	□	□
TD-R14a	960 x 2660	900 x 2600	□	1000 x 2700		□	□	□	□
TD-R15	960 x 2960	900 x 2900	□	1000 x 3000	1000 x 3000	□	□	□	□
TD-R15m	1010 x 2510	950 x 2450	□	1050 x 2550		□	□	□	□
TD-R16	1060 x 1360	1000 x 1300	■	1100 x 1400	1150 x 1450	■	■	■	□

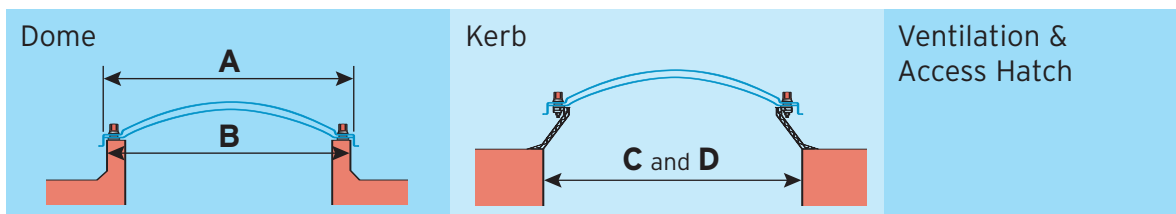

Size Ref No.	Dimension A	Dimension B	Rooflight stock availability	Dimension C (PVC)	Dimension D (GRP)	Kerb stock availability	Controlled ventilation	Opening ventilation	Access hatch
TD-R16a	1060 x 1660	1000 x 1600	■	1100 x 1700	1150 x 1750	■	■	■	
TD-R16b	1060 x 1960	1000 x 1900	□	1100 x 2000	1150 x 2050	□	□	□	
TD-R16e	1060 x 2260	1000 x 2200	□	1100 x 2300		□	□	□	
TD-R17	1160 x 1460	1100 x 1400	■△	1200 x 1500	1250 x 1550	■	■	■	
TD-R17a	1160 x 1660	1100 x 1600	□	1200 x 1700		□	□	□	
TD-R18	1160 x 1760	1100 x 1700	■△	1200 x 1800	1250 x 1850	■	■	■	
TD-R18a	1160 x 2060	1100 x 2000	□	1200 x 2100	1250 x 2150	□	□	□	
TD-R19	1160 x 2160	1100 x 2100	□△	1200 x 2200	1250 x 2250	□	□	□	
TD-R20	1160 x 2360	1100 x 2300	■△	1200 x 2400	1250 x 2450	■	■	■	
TD-R21	1160 x 2460	1100 x 2400	□	1200 x 2500	1250 x 2550	□	□	□	
TD-R22	1160 x 2660	1100 x 2600	□	1200 x 2700	1250 x 2750	□	□	□	
TD-R22a	1160 x 2960	1100 x 2900	□	1200 x 3000		□	□	□	
TD-R22z	1160 x 3160	1100 x 3100	□	1200 x 3200		□	□	□	
TD-R22p	1210 x 1810	1150 x 1750	□	1250 x 1850		□	□	□	
TD-R22r	1210 x 2410	1150 x 2350	□	1250 x 2450		□	□	□	
TD-R22x	1260 x 1560	1200 x 1500	□	1300 x 1600		□	□	□	
TD-R22b	1260 x 1860	1200 x 1800	■△	1300 x 1900		■	■	■	
TD-R22c	1260 x 2460	1200 x 2400	■	1300 x 2500		□	■	□	
TD-R23w	1360 x 1560	1300 x 1500	□	1400 x 1600		□	□	□	
TD-R23x	1360 x 1660	1300 x 1600	□	1400 x 1700	1450 x 1750	□	□	□	
TD-R23	1360 x 1960	1300 x 1900	□	1400 x 2000	1450 x 2050	□	□	□	
TD-R23a	1360 x 2260	1300 x 2200	□	1400 x 2300	1450 x 2350	□	□	□	
TD-R23b	1360 x 2560	1300 x 2500	□	1400 x 2600		□	□	□	
TD-R24	1460 x 1760	1400 x 1700	□	1500 x 1800	1550 x 1850	□	□	□	
TD-R25	1460 x 2060	1400 x 2000	□	1500 x 2100	1550 x 2150	□	□	□	
TD-R26	1460 x 2160	1400 x 2100	□	1500 x 2200	1550 x 2250	□	□	□	
TD-R27	1460 x 2360	1400 x 2300	□	1500 x 2400	1550 x 2450	□	□	□	
TD-R28	1460 x 2460	1400 x 2400	□	1500 x 2500	1500 x 2500	□	□	□	
TD-R29	1460 x 2660	1400 x 2600	□	1500 x 2700	1550 x 2750	□	□	□	
TD-R30	1460 x 2960	1400 x 2900	□	1500 x 3000	1550 x 3050	□	□	□	
TD-R31x	1760 x 2060	1700 x 2000	□	1800 x 2100	1850 x 2150	□	□	□	
TD-R31	1760 x 2160	1700 x 2100	□	1800 x 2200	1850 x 2250	□	□	□	
TD-R32	1760 x 2360	1700 x 2300	□	1800 x 2400	1850 x 2450	□	□	□	
TD-R32a	1760 x 2460	1700 x 2400	□	1800 x 2500	1850 x 2550	□	□	□	
TD-R33	1760 x 2660	1700 x 2600	□	1800 x 2700	1850 x 2750	□	□	□	
TD-R34	1760 x 2960	1700 x 2900	□	1800 x 3000	1850 x 3050	□	□	□	

Availability

■● available ex-stock, 1 to 5 days delivery □○ available to order, 7-28 days delivery △ available in pyramid form
 Bronze anti-glare domes = 14 to 28 days delivery. For powered ventilation, burglar bars and multiple rooflights please consult National Domelight Company.

Limitation on use

Thermadomes and related products as described in National Domelight Company's literature are designed for use in normal circumstances on flat roofs up to 15° pitch. For applications in excess of 15° or in unusual circumstances (e.g. extreme temperature or climatic conditions) please refer to National Domelight Company. Please note that all information supplied is based on our best knowledge and general experience.

Because of factors outside our control which can affect installation and use of products, no warranty is given or implied in respect of information provided. A policy of continuous product improvement applies and National Domelight Company therefore reserve the right to alter specifications without prior notice.

Guarantee

All Thermadome rooflights, when installed on Therma-kerbs or Alu-kerbs and in accordance with manufacturers' instructions, are guaranteed

against the effects of defective design, materials or construction for a period of ten years from date of supply by National Domelight Company.

Furthermore, the glazing element of all Thermadomes is warranted against discolouration for ten years subject to certain conditions. A twenty year 'special projects' guarantee is also available. Further details available on request.

All other products (e.g. ventilation systems and other accessories) are guaranteed for 12 months from date of supply by National Domelight Company.

Technical services

Advice and technical assistance is always available from National Domelight Company on the application and specification of Thermadome rooflights and accessories.





Pyramid House,
52 Guildford Road,
Lightwater,
Surrey GU18 5SD
Tel: 01276 451555
Fax: 01276 451533

e-mail: info@nationaldomes.com
www.nationaldomes.com